



Vacumobil 140/160

Dust extractor

2,2 kW (IE4)

H3 certified

HÖCKER[®]
POLYTECHNIK

Always one idea ahead

Vacumobil 140/160

Enhanced performance, reduced consumption.

The innovative Vacumobil 140/160 dedusters by Höcker Polytechnik set entirely new standards in extraction for wood processing machines and air filtration. They feature numerous improvements in regards to energy efficiency, equipment size, performance characteristics and application flexibility.

Higher throughput is achieved by a housing interior optimised for airflow. Standard energy-saving drives (IE4) reduce electricity consumption. Our Vacumobiles ensure an extremely environmentally friendly and energy-saving operation.

Vacumobil VT 140/160

- For installation in the shop, also for explosion-prone dust-air mixtures and intermittent processes during breaks, the system gently cleans the filters by means of vibration without the use of compressed air
- Deposition of dust and chippings in stable bin interleaved foil bag

Illustration bottom:
Vacumobil VT 140/160 with
2.2 kW energy-saving motor (IE4)



Illustration bottom:
The suction connection with 140 mm in diameter can be removed and a 160 mm tube or suction pipe can be connected.



Safety with a capital S

The Vacumobil can be installed in the shop without additional fire protection measures. It is supplied ready to connect with a phase changing plug. The standard contactor control ensures automatic start-up and safe operation. Inputs for automatic start-up using potential-free contacts are included as standard equipment.



Advantages

- Installation in the work area is allowable (depending on the type of dust)
- Low residual dust content < 0.1 mg/m³ (H3) according to the Technical Guideline for the Handling of Hazardous Materials (TRGS) 553
- 100% utilisation of heat energy through air recirculation
- Large collection volume with 1 mobile collecting bin
- Low height, less than 2 m (height, middle of intake port: 1.5 m)
- Controller, standard with automatic start-up (potential free contact)
- No pressure relief required for St1 dust
- Filter material tested by the Employer's Liability Insurance Association (BG) (99.95% separation)
- Low energy consumption and high extraction performance
- Drive Efficiency Class IE4
- Automatic filter cleaning

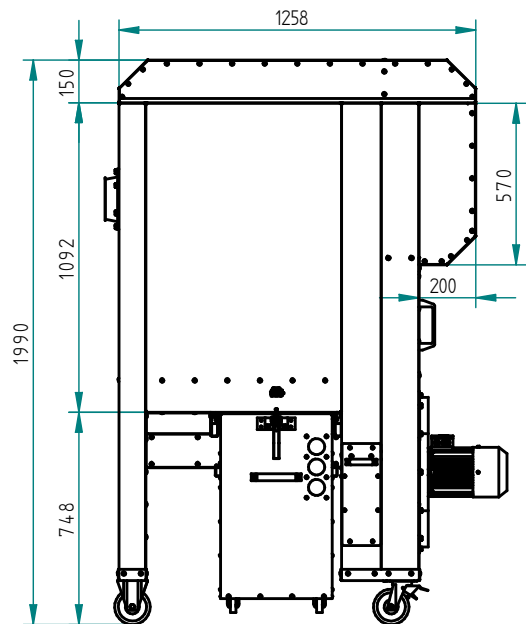
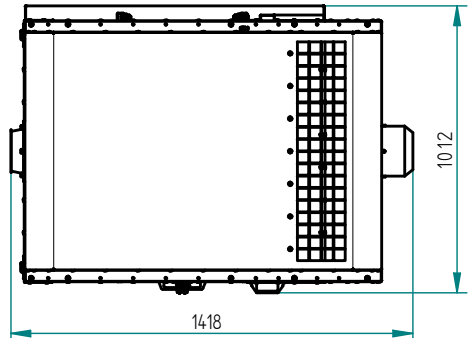

	Vacumobil VT 140/160
Suction connection diameter	140 mm (160 mm when removing connecting piece)
Engine-rating	2.2 kW / 400 V / 50 Hz (IE4)
Filter area	ca. 7 m ²
Nom. Volume Flow (V Nom)	1.100 m ³ /h with 140 mm suction opening
Max. Volume Flow (V Max)	1.950 m ³ /h with 160 mm suction opening
Vacuum generated V Nom**	ca. 2.800 Pa
Vacuum generated V Max**	ca. 1.500 Pa
Collection Volume	ca. 175 litre
Maximum sound pressure level*	< 73 dB(A)
Measurements (L x W x H)	1.418 x 1.012 x 1.990 mm
Weight	ca. 350 kg
Dedusting	Vibration
Slide valve gear	standard (potential-free contact)

* Measured according to the EU Machinery Directive subject to free field conditions with 1m distance of 1.6m height
 ** In delivery status – non-impinged filter hoses



Höcker Polytechnik GmbH
Borgloher Straße 1
49176 Hilter a.T.W.
Germany

phone +49 5409 405 0
email info@hpt.net



www.hoecker-polytechnik.com

HÖCKER[®]
POLYTECHNIK

Always one idea ahead